

AutoCAD Civil 3D 2010 Education Curriculum Instructor Guide Unit 3: Land Development

Lesson

8

Autodesk

Pipe Design

Overview

In this lesson, students learn how to add pipes and structures to a pipe network in plan view and in profile view. Students also learn how to label the pipes and structures in both views. The Hydraflow Storm Sewers Extension is used to calculate pipe sizes and invert elevations for a storm sewer pipe network. You create a pipe network to model storm sewer, sanitary sewer, and water main systems. By creating a 3D model of a pipe network, you can quickly explore different design alternatives and check for interferences with other subsurface features.

The following illustration shows a pipe network in plan, profile, and 3D views. The arrows indicate the pipe network.

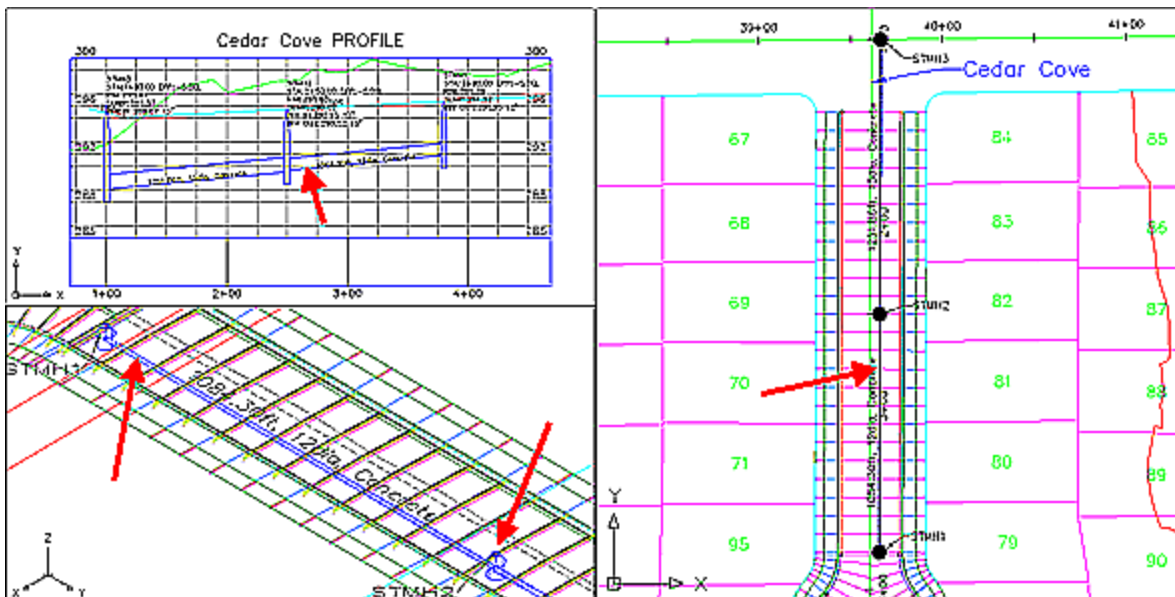

When you draw pipe network parts in profile view, you can evaluate the engineering attributes of your design. You can also customize the appearance of labels to help you design, or meet internal or client CAD standards requirements. When you edit pipe network data, the pipe network objects and labels in plan and profile view automatically update to reflect your revisions. This makes it very easy to generate and evaluate alternatives during the planning and detailed design processes. Furthermore, when you edit the plan view location of pipe network parts, the pipe network parts in the profile view automatically update.

The following illustration shows a pipe network in a profile view.

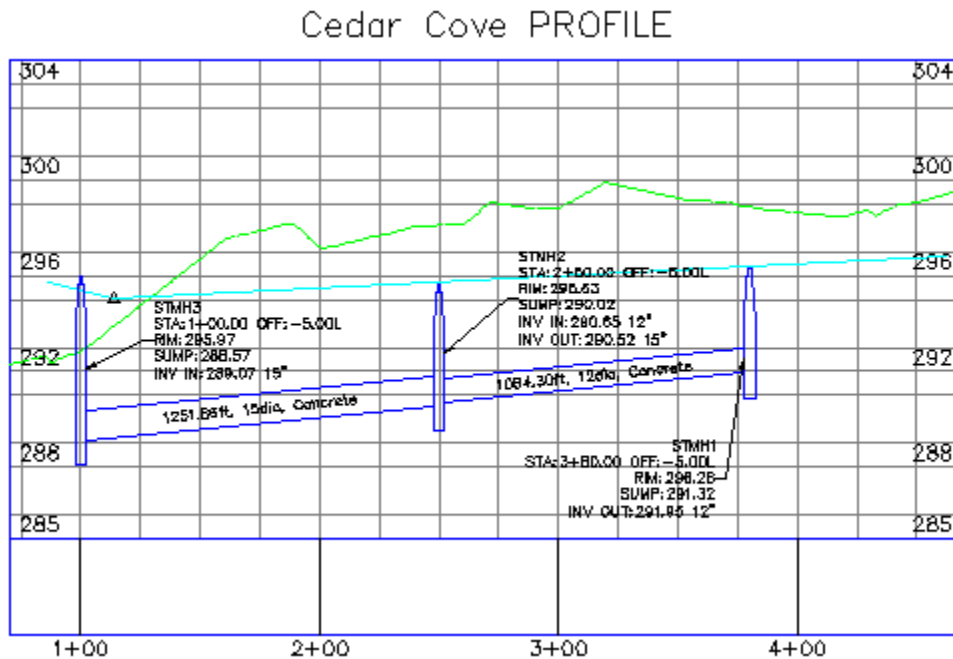

When you label a pipe network, you display the engineering data that you need to complete and evaluate the design and to construct the pipe network. Pipe labels can be created when you create the pipe network or after you create the pipe network. Pipe labels automatically update when you make changes to the pipe network.

The following illustration shows a labeled pipe network.

Cedar Cove PROFILE

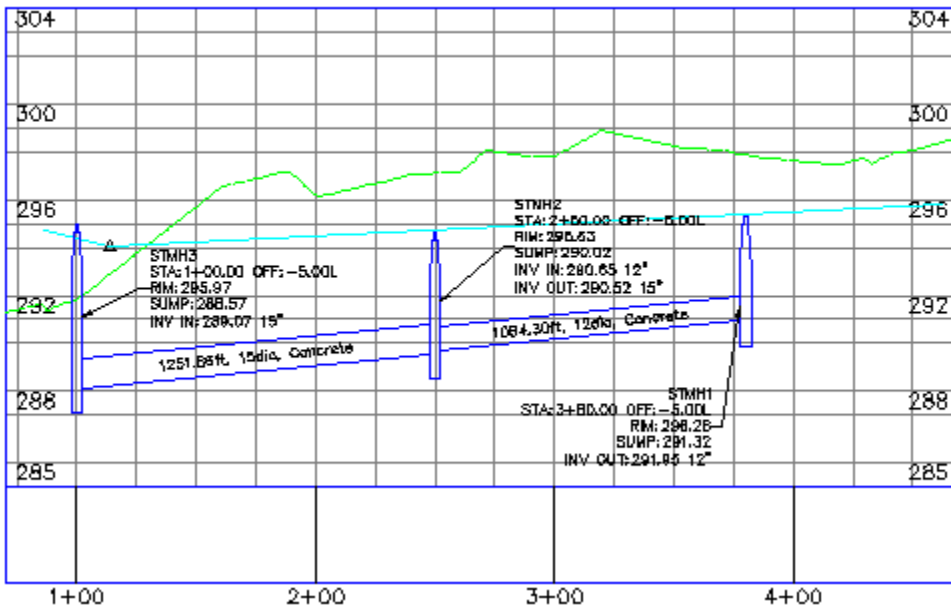

The Hydraflow Storm Sewers Extension is a powerful tool to calculate pipe sizes and invert elevations for a storm sewer pipe network.

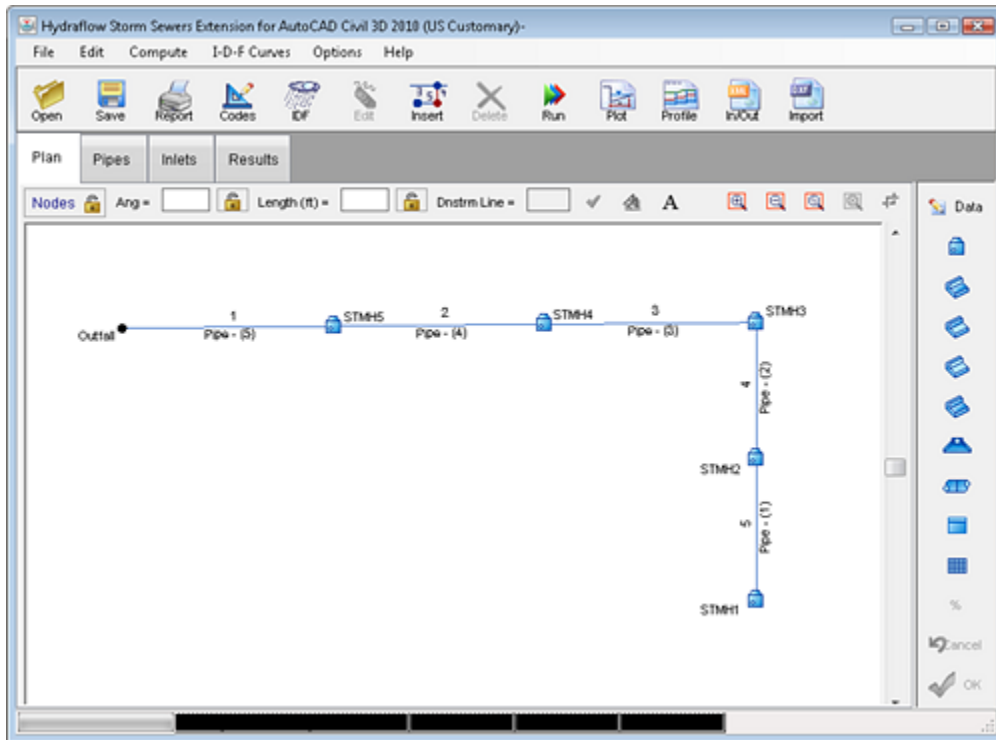

Objectives

After completing this lesson, students will be able to:

- Describe the characteristics and function of pipe network objects.
- List the steps for creating pipe networks.
- Create a storm sewer pipe network for Cedar Cove.
- Draw a pipe network in profile view.
- Edit the pipe network.
- Label pipe networks.
- Design a storm sewer network that includes pipe sizes and invert elevations.

Exercises

The following exercises are provided in a step by step format in this lesson:

1. Create a Pipe Network
2. Draw Pipes in Profile view
3. Edit a Pipe Network
4. Label Pipes
5. Design a Storm Sewer

About Pipe Networks

A pipe network is a system of related pipe and structure parts with properties that define relationships between the network parts, alignments, and surfaces. The following illustration shows the structures for a storm sewer pipe network in Prospector.

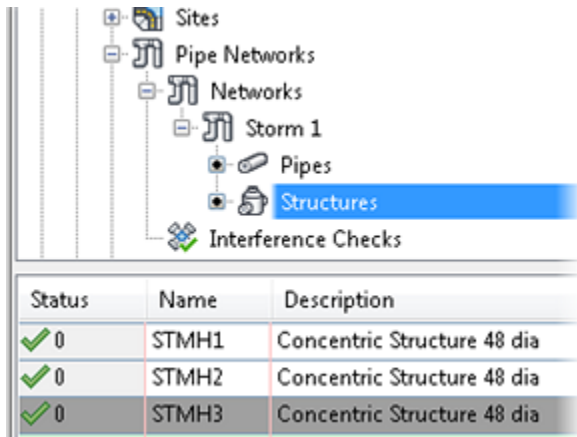

A pipe network defines the relationship between the network parts and the following objects and resources.

Option	Description
Surface	If you configure your pipe network to reference a surface, the elevation data of the surface is used to determine the vertical sizing and placement of network parts. Sizing and placement of parts are calculated using the surface data and design rules for individual parts. For example, manhole rim and pipe invert elevations are calculated directly from the surface elevations using the design rules.
Alignment	A pipe network can take its station data from an associated alignment. Label your network parts to take the station value from the associated alignment.
Labels	You can configure your pipe network to automatically add labels of the selected type to all pipes and structures that you add to the network. You can also add labels later.

The following illustrations show the development of a simple pipe network.

In most cases, a pipe network design starts with another drawing object. In this example, the starting point is an alignment, as shown in the following illustration. The elevations of the pipe network parts created are determined from a surface. The surface can be an existing surface or a corridor surface representing the finished grade.

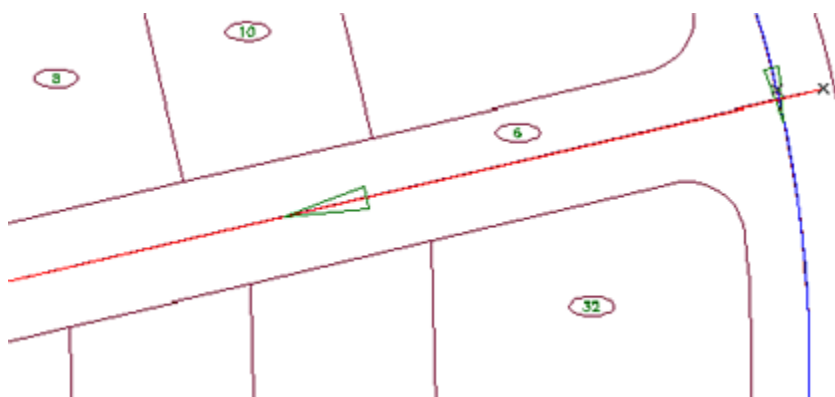

When you use another drawing object as a reference, you can use drawing tools such as object snaps, transparent commands, and tooltips to help you select locations for your pipe network parts. In the following illustration, two structures are selected, creating a network segment with two structures connected by a pipe.

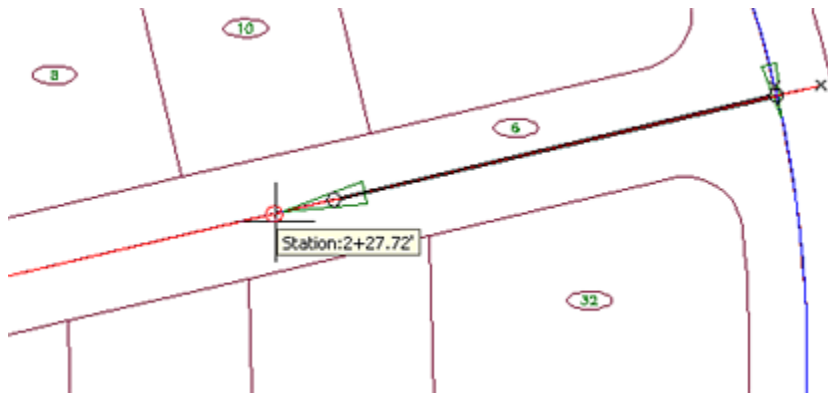

The parts you create are added to the pipe network object in the Prospector tab tree view. When you select the Pipes or Structures items, their properties are displayed in the item view. In the following illustration, the three structures added to the network are displayed.

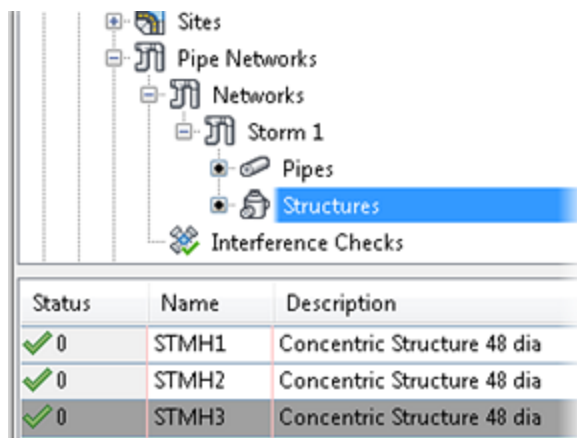

Pipe Network Creation Tools

There are several tools you use to create pipe networks:

- Pipe Network Catalog

The Pipe Network Catalog installs with the software and is external to drawings. It contains all of the available structure and pipe types.

- **Parts List**

You create a parts list and include only those parts that you regularly use to create the pipe network. Your parts list is created based on the parts contained in the pipe network catalog, and is saved in the drawing template DWT file. Parts lists are useful for organizing pipe network parts. You create a separate parts list for storm sewers, sanitary sewers, and water mains.

- **Pipe and Structure Rules (Part Rules)**

Pipe and structure rules govern how the engineering details of a pipe network are calculated when the pipe network is initially created, or when you choose to apply them. The rules also affect how the pipe network parts behave when they are moved or edited. Pipe and structure rules can be associated with the individual pipe and structure parts you add to the Parts List. Pipe rules and structure rules are created independent of each other and are organized into rule sets.

Pipe rules account for the following:

- **Cover and slope:** Minimum/maximum cover and minimum/maximum slopes.
- **Cover only:** Minimum and maximum cover.
- **Length check:** Minimum and maximum pipe lengths.
- **Pipe-to-pipe match:** Pipe drop and connection location (invert, obvert, center) between adjoining pipes.

Structure rules account for the following:

- **Maximum pipe-size check:** Maximum pipe diameter a structure can accommodate.
- **Pipe drop across structure:** Change in elevation between invert in and invert out.
- **Sump depth:** Specify structure sump depth.

Pipe Network Part Creation Modes

You can draft all of the components for a utility network in a single operation using pipe network part creation modes. Depending on the requirements of your pipe network project and your design method, you select one of the following pipe network part creation modes. The mode determines which network parts are added as you create the pipe network.

Option	Description
Pipes and Structures	Use this mode to create network parts by selecting locations for a series of structures. Pipes that connect the structures are created automatically. This mode is useful for quickly creating a simple network such as a "cross-country" branch of a sewer or sanitary system.

Pipes Only	Use this mode to create a network of pipes that are not connected by structures. If you have already created structures, you can use the Pipes Only mode to create connecting pipes to complete or add to the network.
Structures Only	Use this mode to create only structures in your network. You can add pipes to the structures later. For example, you can place all the catch basins required by your project first and add pipes later to create the configuration that is most efficient and uses the smallest quantity of materials.

Null Structures

When you create pipes that connect without structures, a null structure is created. A null structure has no function except to connect two pipes. Null structures appear as simple objects in the drawing area and are listed in the Prospector tab tree view.

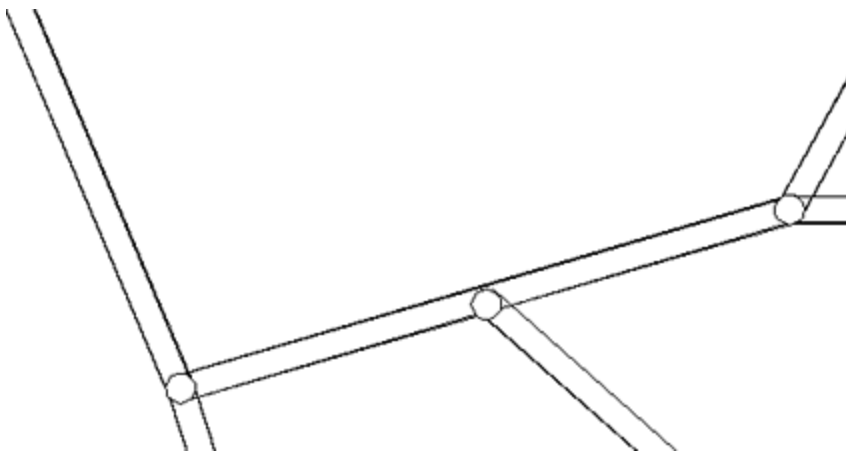

Pipes connected by null structures (2D)

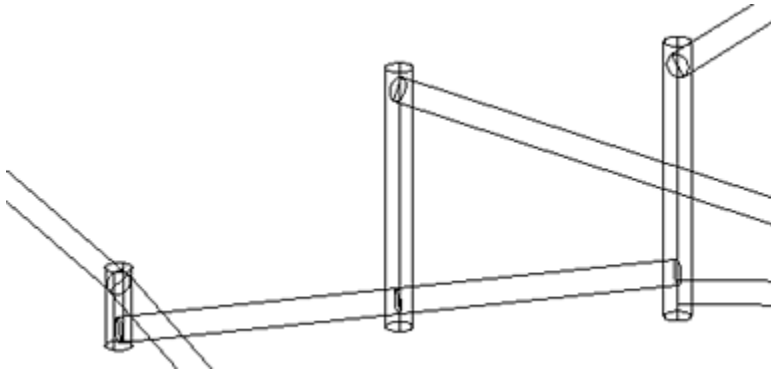

Pipes connected by null structures (3D)

The following illustrations show examples of the Pipes Only and Structures Only pipe network part creation modes. In your design project, if you need to show one or more pipes in another network that may conflict or interfere with your project, you can use the Pipes Only mode to create the required pipes without having to create connected structures. You can also use

Pipes Only mode when you need to create a single, unattached pipe, such as a pipe used as a culvert under a road crossing, as shown in the following illustration.

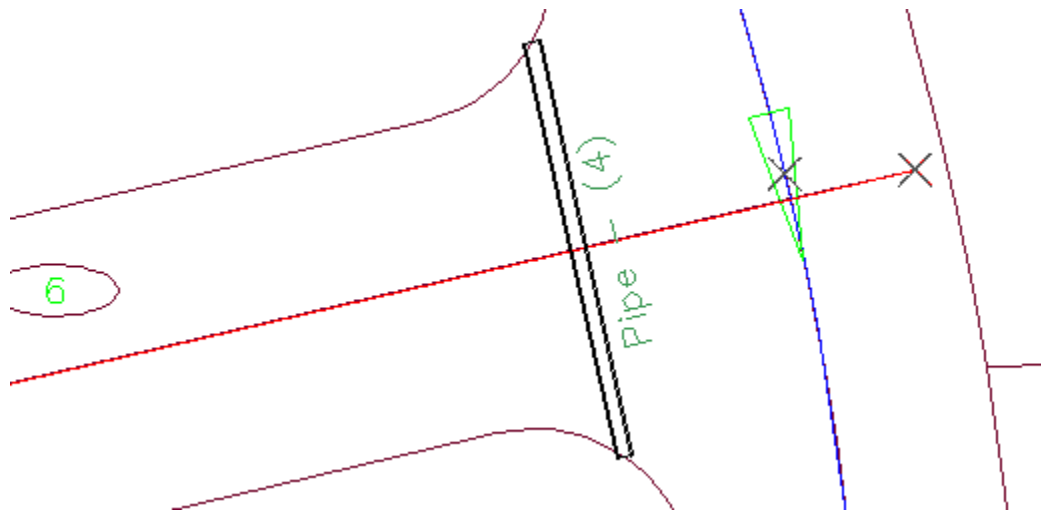

In the following illustration, the designer drew all the required structures without pipes using Structures Only mode.

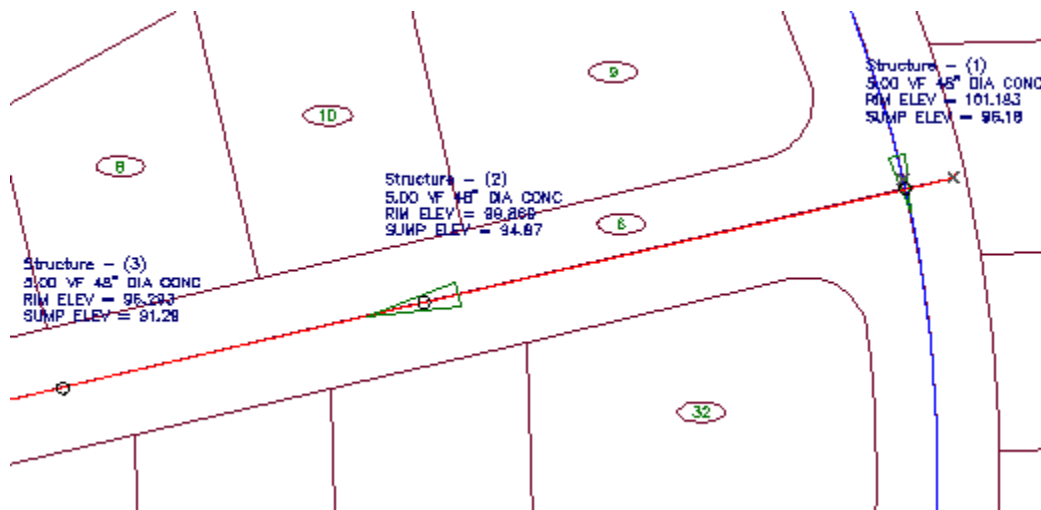

You can add pipes to the design later using Pipes Only mode to make efficient use of space and materials. The completed design is shown in the following illustration.

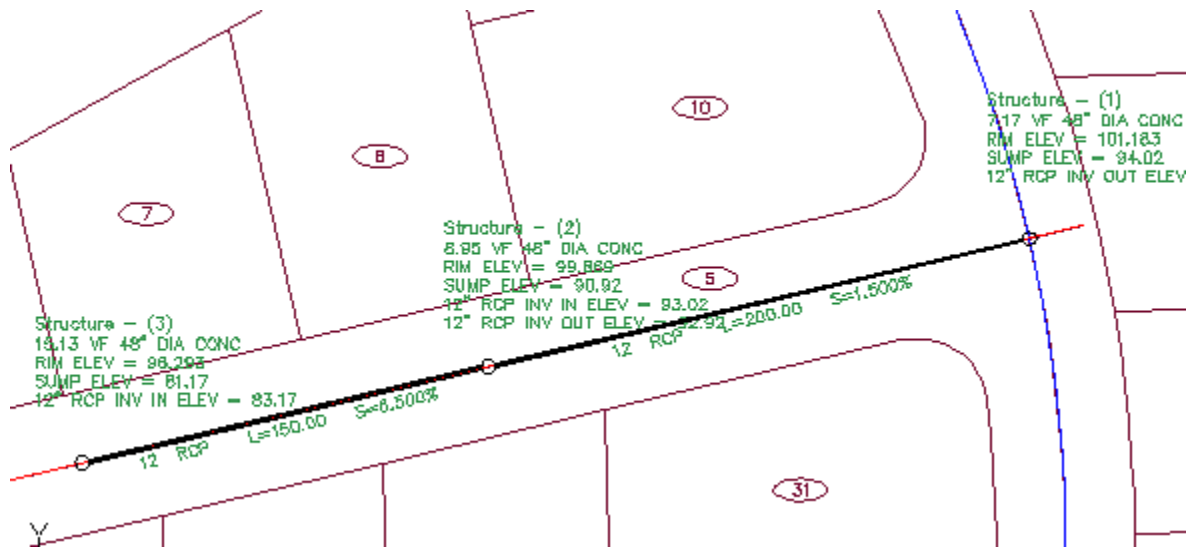

Pipe Networks Not Requiring Structures

You can use Pipes Only mode to create models of entire systems that use only pipes. For example, you can design a water distribution network or a network of conduits that are not pipes, such as electrical lines and fiber optic casings. For a water distribution network, you can draft a design for the network, but the pipe network objects do not model the function of the network.

Creating Pipe Network Parts

The following procedures show you how to create pipe networks. When you create a pipe network, you specify a default parts list that controls which parts you can create, and the surface and alignment data that is referenced as you create network parts. You then add parts to the network using a pipe network part creation mode.

Procedure: Creating a Pipe Network

The following steps describe how to create a pipe network with a default configuration.

1. On the ribbon, Home tab, Create Design panel, click Pipe Network > Pipe Network Creation Tools.

The Create Pipe Network dialog box is displayed.

2. Under Network Name, enter a name for your network.
3. From the Network Parts list, select a parts list that includes the pipes and structures that you want to create.
4. From the Surface Name list, select the default surface that should determine the vertical position of network parts.

5. From the Alignment Name list, select the default alignment to use as a source of stationing data for your pipe network labels.
6. From the Structure Label Style list, select the label style to add automatically to structures as they are created.
7. From the Pipe Label Style list, select the label style to add automatically to pipes as they are created.

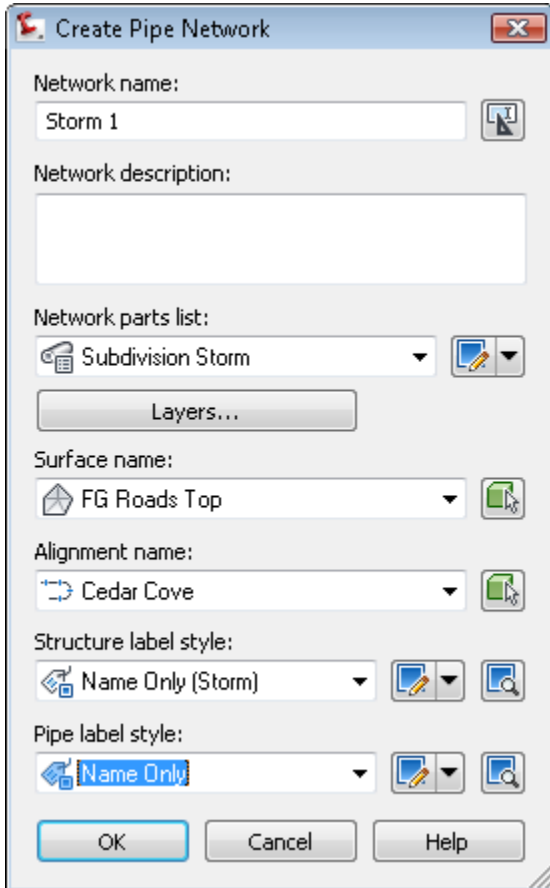

Procedure: Creating Parts in a Pipe Network

The following steps describe how to create parts for a pipe network using the Pipes and Structures pipe network part creation mode. You create parts by selecting locations for structures, which are then connected by pipes.

1. On the Network Layout Tools toolbar, from the Structures list, select the type of structure to create.
2. From the Pipes list, select the type of pipe to use to connect the structures.

3. Set the Toggle Upslope/Downslope button to create pipes that travel in the required direction.
4. From the list of pipe network part creation modes, select Pipes and Structures.

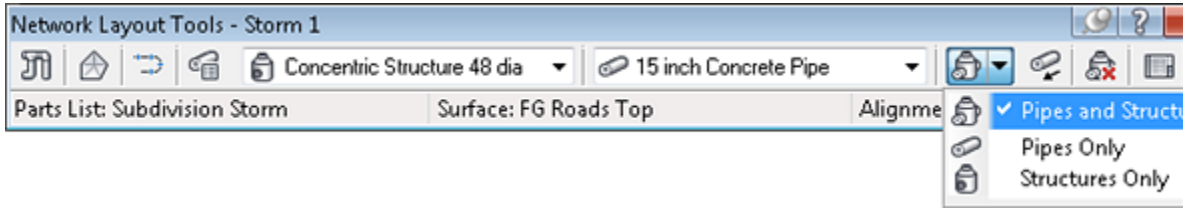

5. In the drawing area, click the location for the first structure.
A structure is created at the location. The vertical placement of the structure is determined from the elevation data of the referenced surface.
6. Click the location for a second structure.
A structure is created at the second location. A pipe is created that connects the first and second structures. The elevation and grade of the pipe are determined using the referenced surface and the design rules for the selected pipe type.
7. Add additional structures as required. You can change the type of structure and pipes that are created as you continue with your layout.

Procedure: Creating a Pipes Only Network

The following steps describe how to use the Pipes Only pipe network part creation mode.

1. In the drawing area, click a pipe network part.
2. On the Network Layout Tools toolbar, from the Pipes list, select the type of pipe to use to connect the structures.
3. From the pipe network part creation modes list, select Pipes Only.

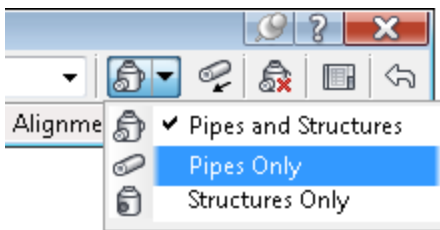

4. Click the location for the start point, then the endpoint of the pipe.
The pipe is created. The endpoint of the current pipe is the start point for the next pipe you draw.
5. Click the location for the endpoint of the second pipe.

The first and second pipe are joined with a null structure.

6. To select a start point that is disconnected from the previous pipe, on the command line, enter **s**. Click the start point for the next pipe.

Procedure: Creating a Structures Only Network

The following steps describe how to use the Structures Only pipe network part creation mode.

1. In the drawing area, click a pipe network part.
2. On the Network Layout Tools toolbar, from the Structures list, select the type of structure to create.
3. From the Pipe Network Part Creation Modes list, select Structures Only.

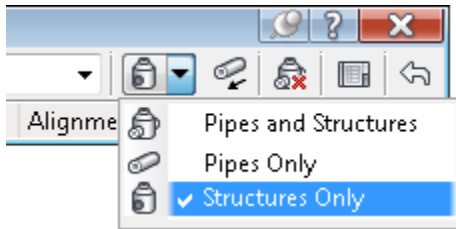

4. In the drawing area, click the locations for structures, as required.

Guidelines

Keep the following guidelines in mind when you create pipe networks:

- When you create a pipe network, use the Station and Offset transparent command on the Transparent Commands toolbar to create structures based on a fixed offset from an alignment.
- When you create the drawing template for your organization, include parts lists that contain the pipe and structure parts your team would use on a regular basis.
- You can automatically check for interferences between multiple pipe networks using Pipes menu > Utilities > Create Interference Check.
- To keep drawings free of annotation, create tables that show pipe network data.

The following illustrations show the development of pipe networks using two pipe network part creation modes. In the following illustration, structures have been created at regular intervals along the alignment without pipes using the Structures Only pipe network part creation mode.

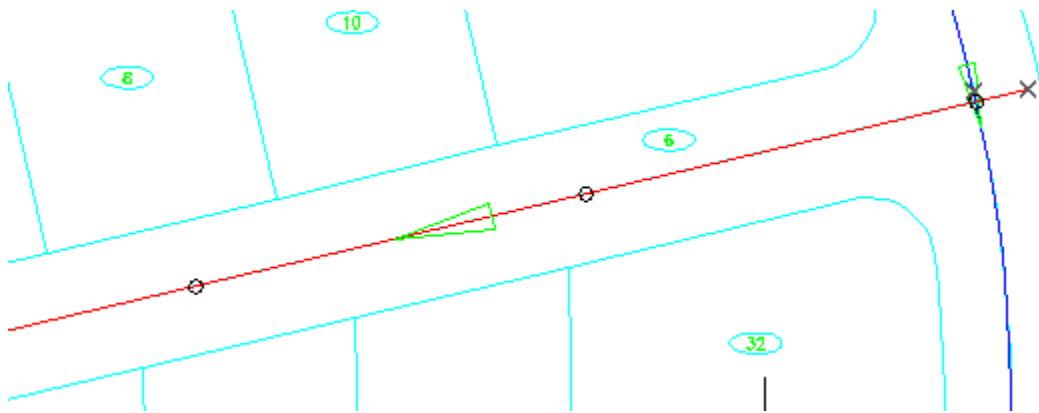

Using the Pipes Only pipe network part creation mode, the structures are connected to create the final network design, as shown in the following illustration.

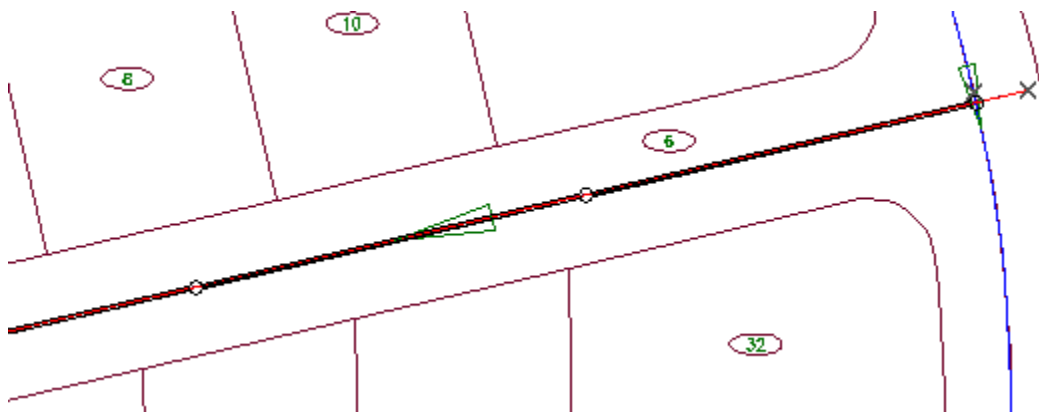

In the next illustration, a second pipe network is created to show the placement of culverts in the project. This network is made up of single pipes created using the Pipes Only pipe network part creation mode.

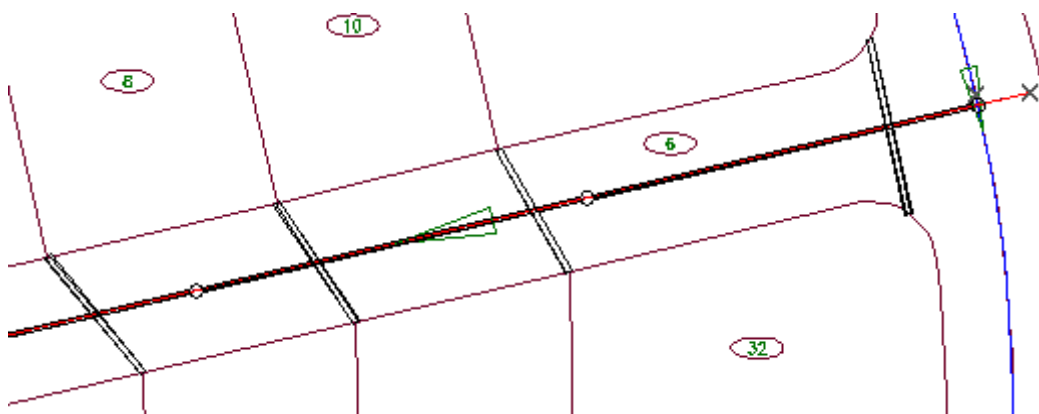

Drawing Pipe Networks in Profile View

When you create a pipe network, you first always draw the pipe network in the plan view by positioning pipe network structures and connected pipes. The initial pipe invert elevations and pipe slopes are calculated using pipe and structure rules. After you draw the pipe network in the plan view, you use the Draw Parts in Profile command to draw the pipe network parts in profile view.

You can either draw individual network parts or the entire pipe network in profile view. You can draw pipe network parts in any profile view. This is useful when you want to show crossing pipes for intersecting alignments.

Editing Pipe Networks

You can edit a pipe network either graphically or by changing the pipe data in a table.

Graphical Edits

To edit a pipe network graphically in plan view, select the pipe network part in the drawing area to activate the grips. Pipe network structures and pipes each have their own grips. When you edit a pipe network graphically, the tabular data is automatically updated.

Pipe structure grips for plan view graphical editing are shown in the following illustration:

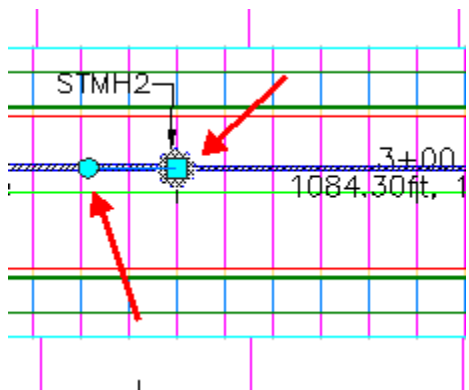

You use the circular grip to rotate the structure. This is useful for asymmetrical structures and structure styles that display text. You use the square grip to change the location of the structure. When you move a structure, connected pipes move with the structure. Profile structures and pipe locations and associated annotation automatically updates.

Note: When you use grips to change the location of pipes in plan view, you disconnect the structure from the pipe.

There are similar grips that can be used to graphically edit structures and pipes in the profile view. These are shown in the following illustration:

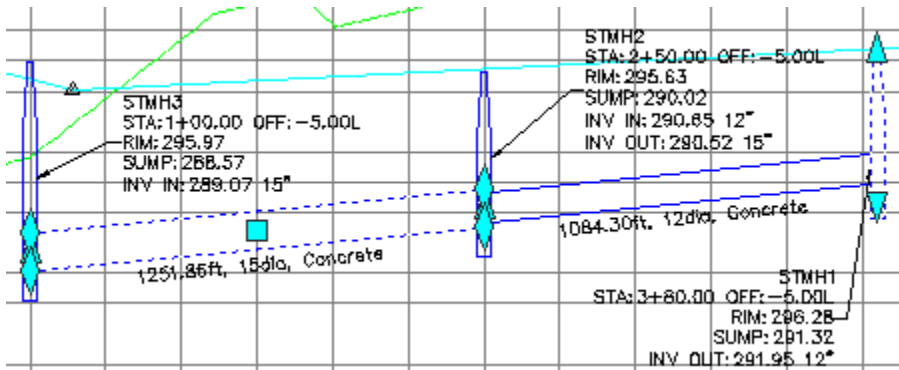

You use diamond-shaped grips on pipe parts to change the invert and obvert elevation for each end of the pipe. This results in a pipe grade change. You use the square grip on the pipe part to change the invert and obvert elevations at both ends of the pipe. This maintains the pipe grade. You use the triangle shape grips on the structure pipes to change the rim and sump elevations.

Data Table Edits

There are several options for editing pipe network data in a table. When you edit pipe network data in a table, the graphical display of the pipe and structure objects, and associated annotation, automatically updates.

You can edit pipe and structure data on the Prospector tab of the Toolspace window.

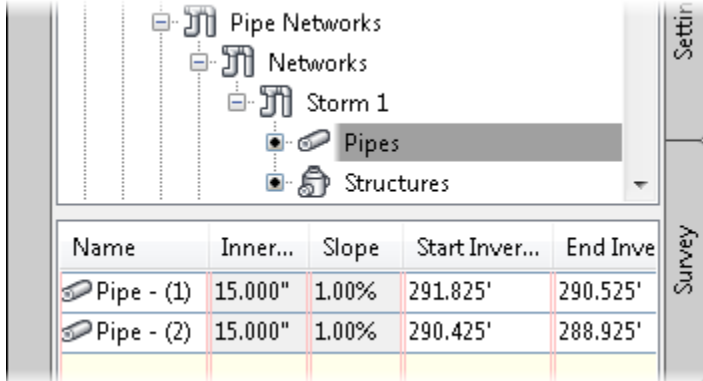

You can also edit the Pipe Properties or Structure Properties. Each dialog box displays the engineering properties of the pipe or structure. The Pipe Properties dialog box is shown in the following illustration:

Pipe Properties	Value
Start Invert Elevation	291.825'
End Invert Elevation	290.525'
Start Crown Elevation	293.075'
End Crown Elevation	291.775'
Pipe Start Easting	1696477.2281'
Pipe Start Northing	17831677.6388'
Pipe End Easting	1696477.5218'
Pipe End Northing	17831807.6385'
Start Centerline Elevation	292.450'
End Centerline Elevation	291.150'

You can open the Panorama window to edit both pipe and structure parts. You can also set and preconfigure data column configuration to show the pipe network data you need. The Panorama window is shown in the following illustration:

Status	Name	Descripti...	Style
✓ 0	MHSTM1	Concentric	Storm Sewe E
✓ 0	MHSTM3	Concentric	Storm Sewe E
✓ 0	MHSTM2	Concentric	Storm Sewe E

Guidelines

Keep the following guidelines in mind when you draw and edit pipe networks:

- A single pipe style controls the display of pipe parts in plan, profile view, and section view. A single structure style controls the display of structure parts in plan, profile view, section view, and 3D views.
- Pipe styles and structure styles should be developed and saved in your company/client DWT drawing template.

- When you edit pipe network data in Prospector and Panorama, you can control and pre-configure the data columns to display.
- To provide additional engineering details for the construction of the pipe network, draw pipes and structures in profile view.

About Pipe Labels

You create pipe labels to convey engineering and design information. You can label any property of a pipe network, structure, or pipe, in plan or profile view. In plan view, you typically label manhole and catch basin identification numbers. For pipes, you typically label the length, description (type), and slope. In profile views, you typically label the same information, as well as the invert elevations at the structure locations and rim elevations.

You create pipe labels when you create the pipe network, or after you create the pipe network. Pipe labels automatically update when you make changes to the pipe network.

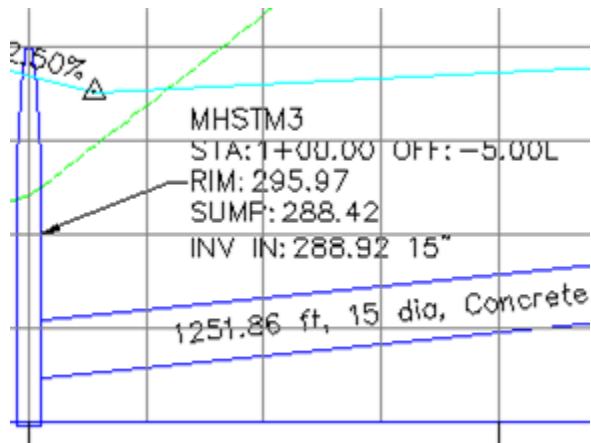

Labeling Pipes

You use pipe label styles to label pipe network pipes, and you use structure label styles to label pipe network structures. Pipe and structure label styles are found in the Settings tab of Toolspace. This is shown in the following illustration:

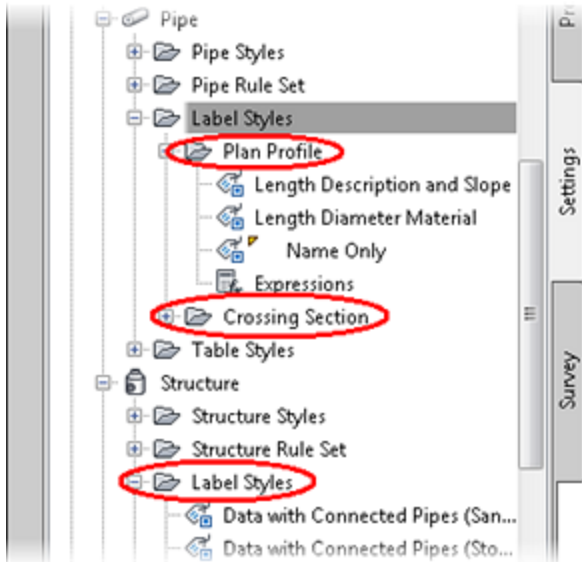

If you need to show different pipe and structure data in plan and profile, you create separate pipe and structure labels for plan and profile views. You can also create pipe label styles to label crossing pipes in the profile view.

Guidelines

Keep the following guidelines in mind when labeling pipes:

- Modify the command settings for pipe networks to set the default pipe and structure label styles. When you do this, the correct label styles are automatically applied when you label the pipe network.
- Use spanning labels to label lengths and slopes over multiple pipe segments. Spanning labels are useful when you want to label the length of an entire pipe network that spans several structures, or if you want to label a pipe network with null structures, such as a water-main network.

About Storm Sewer Networks

This section describes storm sewer networks and the Hydraflow Storm Sewers Extension. You use the Hydraflow Storm Sewers Extension to analyze and calculate storm sewer pipe networks to ensure pipe diameters and invert elevation support designated flow rates.

Storm sewer networks are a series of connected catch basins, manholes, and pipes used to discharge storm water to an outfall location. Pipe diameters and invert elevations in a storm sewer network are calculated based on hydrologic and hydraulic analysis.

Design Calculations

The design of a storm sewer network involves the calculation of pipe diameters and rim elevations from input flow data. When you create a pipe network in Civil 3D, you individually select pipe sizes from a list. Invert elevations are typically calculated based on minimum depth of cover and drop across structure rules. However, to meet the requirements of a storm sewer, network pipes must be resized and invert elevations must be recalculated using appropriate hydrologic and hydraulic analysis.

You can either manually enter flow data or use Hydraflow Storm Sewers Extension to calculate the values using traditional methods.

Hydraflow Storm Sewers Extension

The Hydraflow Storm Sewers Extension:

- Is a Civil 3D extension that can read pipe network geometry, pipe types, and structure types created in a Civil 3D pipe network.
- Performs hydraulic analysis of both simple and complex storm sewer networks.
- Can calculate pipe diameters, invert elevations, and energy grade lines for up to 250 connected storm sewer lines.

The following images show a storm sewer network in Hydraflow Storm Sewers Extension in different views.

The first image shown is the layout of a storm sewer network in plan view.

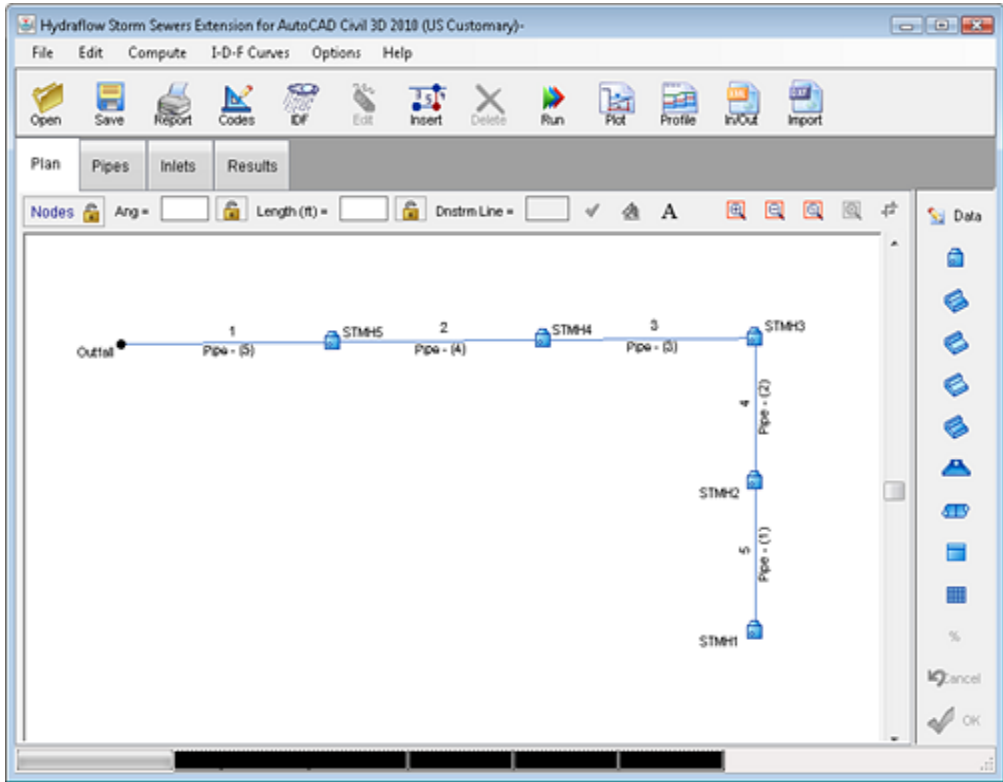

The following image shows a storm sewer network in profile view.

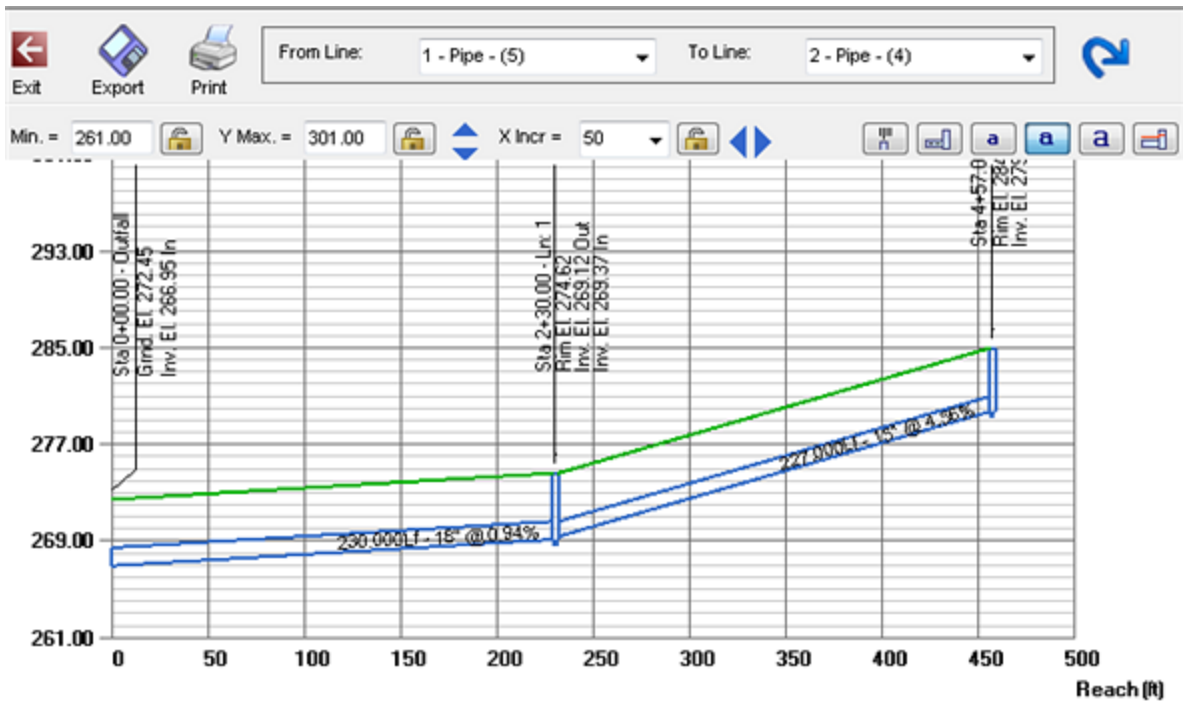

The following image shows the pipe data for the same storm sewer network. You can either input the flow data manually, or you can use Hydraflow Hydrographs Extension to calculate the surface runoff and resultant flow to the individual pipes in the pipe network.

Line No.	Line ID	Dnstr Line No.	Line Length (ft)	Defl Angle (deg)	Junction Type	Known Q (cfs)	Drnge Area (ac)	Runoff Coeff (C)	Tc Method	Inlet Time (min)	Invert Elev Dn (ft)	Li Slc (C)
1	Pipe - (5)	Outfall	230.000	-0.569	Manhole	2.50	0.00	0.00	User	0.0	266.95	0.
2	Pipe - (4)	1	227.000	0.000	Manhole	2.00	0.00	0.00	User	0.0	269.37	4.
3	Pipe - (3)	2	229.149	0.015	Manhole	1.50	0.00	0.00	User	0.0	279.97	4.
4	Pipe - (2)	3	145.000	90.683	Manhole	1.00	0.00	0.00	User	0.0	290.34	0.
5	Pipe - (1)	4	150.000	0.000	Manhole	0.50	0.00	0.00	User	0.0	290.63	0.

Designing a Storm Sewer Network

This section describes a process for laying out and designing storm sewer networks using Civil 3D and Hydraflow Storm Sewers Extension. When you design a storm sewer network, you lay out the pipe network in Civil 3D, export the pipe network to Hydraflow Storm Sewer Extension to calculate flow values for the network, and import the Hydraflow Storm Sewers Extension pipe network to Civil 3D.

Process: Designing a Storm Sewer Network

Laying out and designing a storm sewer network involves working in both Civil 3D and Hydraflow Storm Sewers Extension. To lay out and design a storm sewer network, you follow these steps:

1. Layout the pipe network in Civil 3D using the Pipe Network Creation Tools.



- Export the pipe network to a Hydraflow Storm Sewers Extension project file.

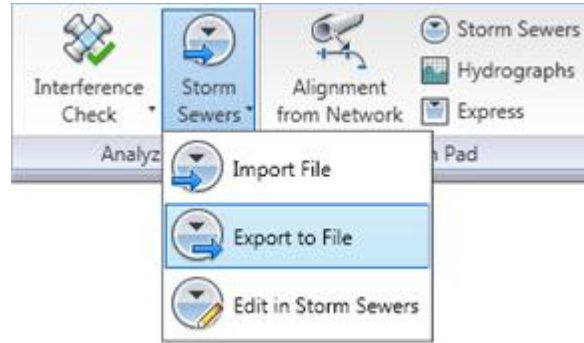

- Start Hydraflow Storm Sewers Extension. Open the project file you exported from Civil 3D. Input the flow values for each pipe.

Line No.	Line ID	Dnstr Line No.	Line Length (ft)	Defl Angle (deg)	Junction Type	Known Q (cfs)	Drng Area (ac)	Runoff Coeff (C)
1	Pipe - (5)	Outfall	230.000	-0.569	Manhole	2.50	0.00	0.00
2	Pipe - (4)	1	227.000	0.000	Manhole	2.00	0.00	0.00
3	Pipe - (3)	2	229.149	0.015	Manhole	1.50	0.00	0.00
4	Pipe - (2)	3	145.000	90.683	Manhole	1.00	0.00	0.00
5	Pipe - (1)	4	150.000	0.000	Manhole	0.50	0.00	0.00

- Compute the pipe sizes, invert elevations, and hydraulic/energy grade lines.

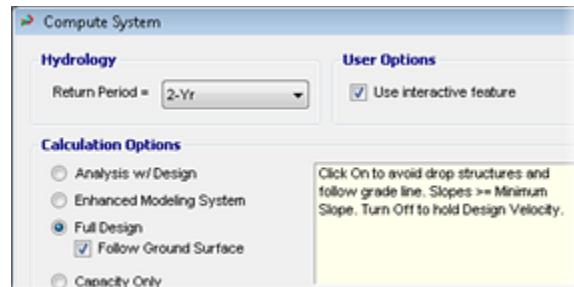

- Export the designed pipe network to a Hydraflow Storm Sewers Extension project file.

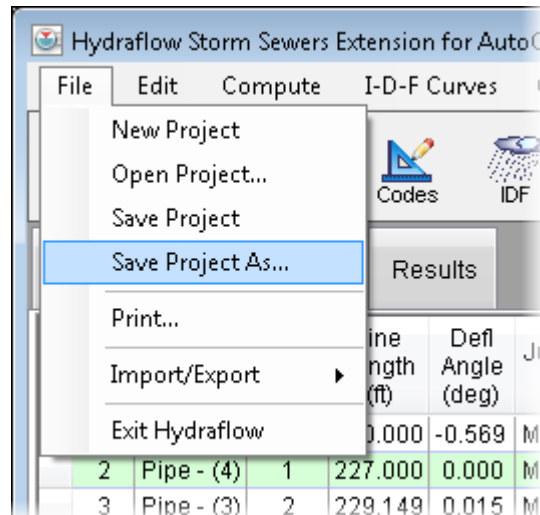

6. Import the pipe network to Civil 3D from the Hydraflow Storm Sewers Extension project file.

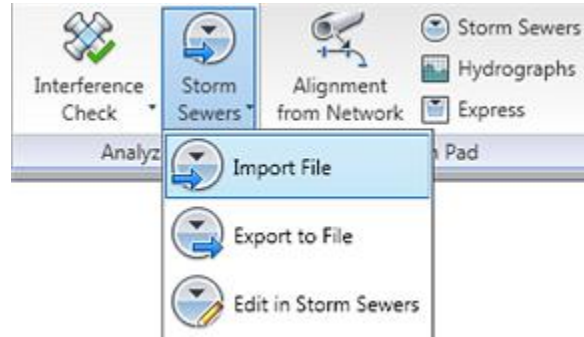

7. Update the storm sewer network with the new data.

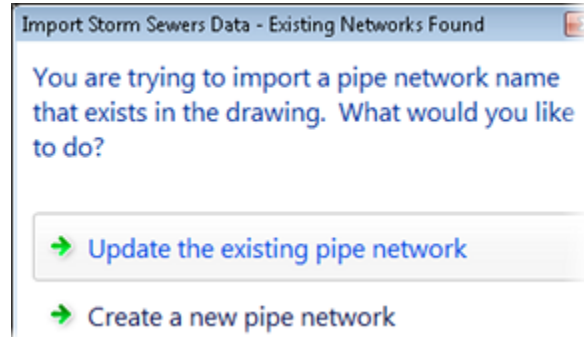

Guidelines

Keep the following guidelines in mind when you create pipe networks:

- Assign the Manning n (smoothness coefficient) value to pipes in the parts list in Civil 3D. When you create a pipe network from parts in the parts list, the Manning n value is transferred to Hydraflow Storm Sewers Extension. Otherwise you need to assign the Manning n value manually in Hydraflow Storm Sewers Extension.
- In Hydraflow Storm Sewers extension, you must specify US Customary for imperial units or SI for metric units.
- In Hydraflow Storm Sewers Extension, ensure your design codes are in accordance with local standards for pipe sizing.

Key Terms

Top Surface	The top surface is a surface that represents the finished design grade and is useful when creating pipe networks. Manhole rim elevations and pipe invert elevations are calculated from the top surface based on minimum depth and slope criteria.
-------------	--

Pipe Network Catalog	Pipes and structures have different dimensions, materials, shapes, and configurations. The Pipe Network Catalog is external to the drawing and contains all possible structure and pipe types.
Parts List	The parts list is set up in the drawing template and contains just the structures and pipes you use in a pipe network. Parts lists are useful for organizing pipe network parts. You create a separate parts list for storm sewers, sanitary sewers, and water mains.
Rim Elevation	The rim elevation is the design elevation for the top of a manhole. The rim elevation is usually determined from a surface that represents the final design grade.
Invert Elevation	The invert elevation is the elevation of the bottom of the pipe at the manhole locations. Each manhole typically has an entering pipe with an invert in elevation and an existing pipe with an invert out elevation.
Transparent Commands	Transparent commands are available on the Transparent Commands toolbar and are used to issue other commands from within a current command. They are typically used to select locations relative to other Civil 3D objects.
Pipe Style	The pipe style controls the display of the pipe in plan, profile, and cross section.
Structure Style	The structure style controls the display of the structure in plan, profile, and cross section.
Part Rules	Pipe and structure part rules set the initial engineering details when a pipe network is created. They also affect how the pipe network parts behave when they are moved or edited.

Exercise 1: Create a Pipe Network

In this exercise, students use the Network Layout Tools to create a storm sewer pipe network for Cedar Cove in plan view. To assist with the creation of the pipe network, students use the Station and Offset transparent command to accurately position the structures adjacent to the alignment.

The completed drawing is as shown.

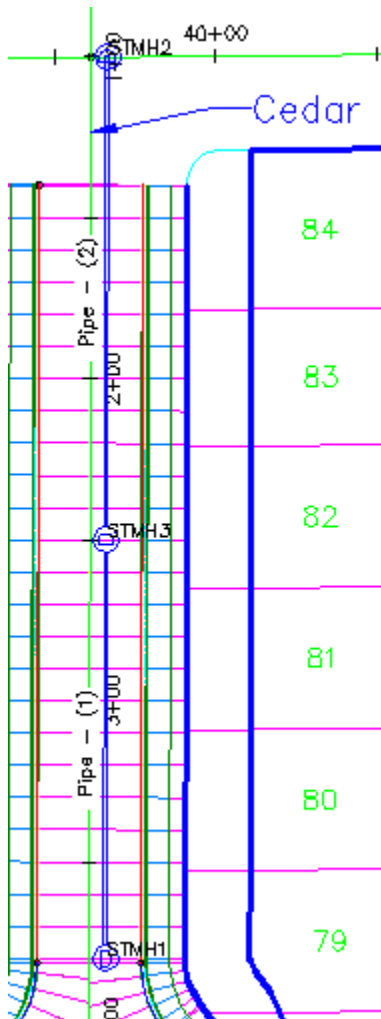

For this exercise, open ...\\I_PipeDesign-EX1.dwg (M_PipeDesign-EX1.dwg).

Students use the Transparent Commands toolbar to help layout the pipe network.

Exercise 2: Draw Pipes in a Profile View

In this exercise, students draw the pipe network in the profile view.

The completed drawing is as shown.

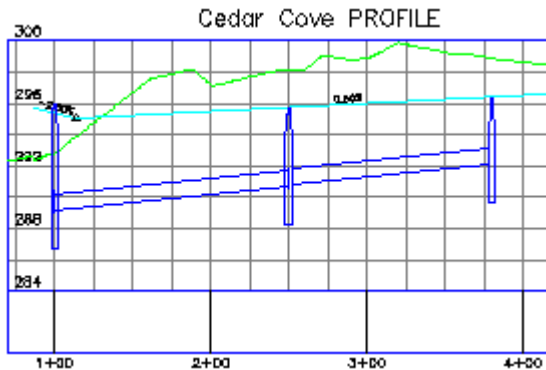

For this exercise, open ...\\I_PipeDesign-EX2.dwg (M_PipeDesign-EX2.dwg).

First, students split the screen into two views.

Exercise 3: Edit a Pipe Network

In this exercise, students edit the pipe network by moving a manhole and changing a pipe size. These edits result in automatic updates to the pipes in the profile view.

The completed drawing is as shown.

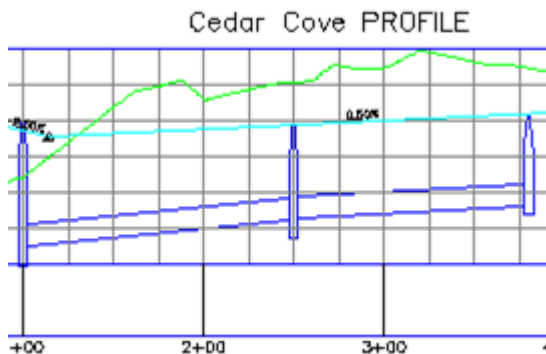

For this exercise, open ...\\I_PipeDesign-EX3.dwg (M_PipeDesign-EX3.dwg).

Exercise 4: Label Pipes

Pipe networks are labeled with structure label styles and pipe label styles. In this exercise, students create and apply label styles to your pipe network in both plan and profile views.

The completed drawing is as shown.

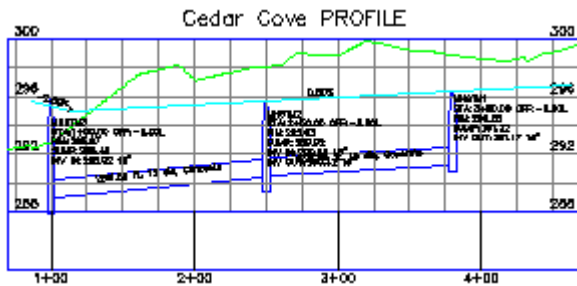

For this exercise, open ...\\I_PipeDesign-EX4.dwg (*M_PipeDesign-EX4.dwg*).

Students begin by creating the labels for the pipes in plan view. Students create and apply a label that shows pipe length, diameter, and material.

Exercise 5: Design a Storm Sewer

In this exercise, students export a basic pipe network to Hydraflow Storm Sewer Extension, compute the storm sewer network values, and import the data to Civil 3D.

The completed drawing is as shown.

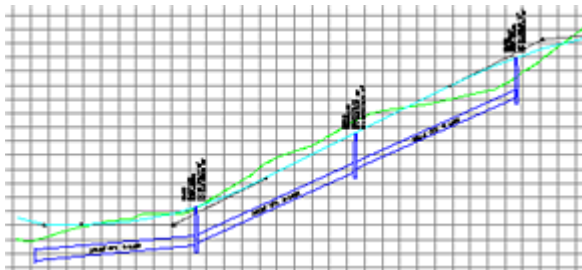

For this exercise, open ...\\I_PipeDesign-EX5.dwg (*M_PipeDesign-EX5.dwg*).

The drawing contains a pipe network that was created using the Civil 3D Pipe Network Creation Tools. Review the pipe network in profile view and note that all pipe diameters are the same.

Assessment

Challenge Exercise

Instructors provide a master or challenge exercise for students to do based on this lesson.

Questions

1. Why is it important for an engineer to have a top surface that represents the finished design grade of a subdivision?
2. Where are all the possible pipe and structure materials, sizes, shapes, and dimensions located?
3. What is the purpose of a parts list?
4. What controls the display of a pipe?
5. Layout of a pipe network occurs in plan or profile view first?
6. When you edit the location of a pipe, will the connected manhole move with it?
7. Where can you edit the style of the labels for pipe in plan view?
8. How does the Hydraflow Storm Sewers Extension interact with Civil 3D?
9. Can the Hydraflow Storm Sewers Extension size storm sewer pipes?

Answers

1. The top surface is used for the calculation of manhole rims and pipe invert elevations.
2. The Pipe Network Catalog.
3. The parts list is set up in the drawing template and contains just the structures and pipes you use in a pipe network. Parts lists are useful for organizing pipe network parts. You create a separate parts list for storm sewers, sanitary sewers, and water mains.
4. The pipe style controls the display of the pipe in plan, profile, and cross section.
5. You must lay out pipe networks in plan view first.
6. No, the pipe moves, but the manhole does not. However, the opposite is true. If you edit the location of a manhole, the connected pipes move with it.
7. In Toolspace, Settings, expand Pipe, Label Styles, and Plan Profile. Then edit to appropriate label style. The Layout tab holds many parameters that can be modified, including the Text – Contents value, which opens the Label Style Composer dialog box.
8. The Hydraflow Storm Sewers Extension requires you to export your pipe network to a *.stm file format. The Extension can open this file and perform calculations and resave the file, at which point, Civil 3D can import the new network information, replacing the previous network.

9. Yes, the Hydraflow Storm Sewers Extension can perform standard hydraulic grade line (HGL) calculations, and compute the capacity and the size of pipes required for the storm sewers.

Lesson Summary

In this lesson, students learned to create, edit, and label pipe networks in AutoCAD Civil 3D software. Students created a storm sewer pipe network consisting of manholes and concrete pipes. Students then edited the pipe network in the plan and profile views. Students also created label styles and labeled the pipes in plan and profile views. Finally, students used the Hydraflow Storm Sewers Extension to calculate the pipe sizes that carry a specified amount of flow and imported the new computed network into Civil 3D.

AutoCAD, AutoCAD Civil 3D, Autodesk, and Civil 3D are registered trademarks or trademarks of Autodesk, Inc., and/or its subsidiaries and/or affiliates in the USA and/or other countries. All other brand names, product names, or trademarks belong to their respective holders. Except as otherwise permitted by Autodesk, Inc., this publication, or parts thereof, may not be reproduced in any form, by any method, for any purpose. Autodesk reserves the right to alter product offerings and specifications at any time without notice, and is not responsible for typographical or graphical errors that may appear in this document.

© 2009 Autodesk, Inc. All rights reserved.